



# Eco-Wave Automatic Pipeline Washer



***Installation & Operation Manual***

---

---

## Table of Contents

General Information .....	3
Features .....	3
Installation.....	4
Change Output Voltage.....	4
Programming.....	5
Rinse Cycle Parameters.....	6
Detergent Cycle Parameters .....	6-7
Acid Cycle Parameters .....	7
Sanitize Cycle Parameters .....	7-8
General Settings Parameters.....	8
Operating Instructions .....	9
Inside the Enclosure .....	9
To change Drain and Diverter Valves from NO to NC.....	10
Technical Support .....	10
Setting Date and Time.....	10
List of All Cycle Parameters and Preprogrammed Settings .....	11-13
Input/Output wiring diagram.....	13
Troubleshooting .....	14
Inside enclosure wiring diagram .....	15
Notes .....	15

### Recommended Spare Parts to Have on Hand

#### Part# Description

10165 - Smart Relay

10168 - Expansion Module

40005 - Complete I/O Board

40009 - MOV Surge Protector for 240VAC

40026 - 3A Fuse 5x20mm

40026-1 - 5A Fuse 5x20mm



# Kleen-Flo Eco-Wave Pipeline Washer

## General Information

The Eco-Wave Pipeline Washer is designed to wash with a wide range of adjustable settings. For example: the length of cycles, etc.

## Features

- ◆ Built in Milk/Wash switch
- ◆ All cycles can be set for cold/hot or mixed water
- ◆ Can be configured for normally open or normally closed drain and diverter valves - see page 10 for instructions
- ◆ Diverter valve can be set with delay
- ◆ Add hot/cold water option if additional water is needed
- ◆ Chemical pump starts 30 sec after water fill starts
- ◆ If fill switch is activated before chemical pump programmed run time is done, cycle will not start until run time is completed
- ◆ Two options for sanitizing - at end of cycle or delay until preferred time of day
- ◆ Sanitizing can be done 1 - 3 times per day
- ◆ Unit has an output to control an engine for powering a line shaft. This output is a dry contact
- ◆ All other output signals are 120/240Vac depending on input voltage
- ◆ Outputs can also be configured for lower voltages (See Page 4)
- ◆ All outputs except engine output can be tested with built in test buttons. Note: no LED with test buttons - see note on pg 9
- ◆ Screen shows cycle and time remaining in cycle
- ◆ Option to manually advance through program for ease of service
- ◆ LED lights indicate which outputs are active
- ◆ Safety switch available for both milk and wash modes
- ◆ Fill switch is 24Vdc and can be used with both float or pressure style switches
- ◆ Air injector settings can be programmed for either existing timer or controlled by washer
- ◆ Removable terminal plugs for ease of installation
- ◆ Option to run milk pump/air blow (Dry Contact)

## Installation

Install Controller in desired location and supply 120/240Vac to unit.  
Power in to the top of the circuit breakers.

Note: By default, Output power = input power. See instructions below for different output voltage.

**Important: Always follow all local electrical codes**

To avoid condensation issues, do not install directly above wash vat.

Engine run signal is a “dry contact” signal.

Vacuum pump signal can be delayed to allow engine to get to full speed before load is applied by using “AdvEngStart” parameter

When all installation/wiring is done and tested for functionality, unit is ready to power up and start programming.

## Changing the output voltage

By default, input voltage equals output voltage. If different output voltage is desired, remove wire jumpers going from “X5” to “X6,Output feed” terminal (see picture below) and apply desired voltage into X6.

Note: The 5 amp fuse is for voltage feeding X6. Extra fuses are included.  
(Inside bag beside the circuit board.)

### Max Output Current

All Outputs Combined: 3A at 240VAC

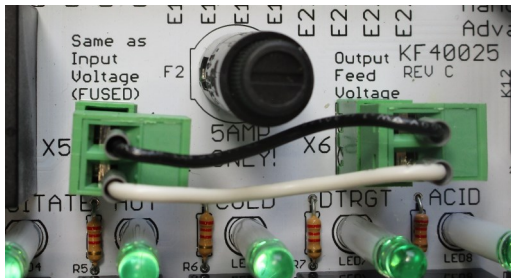

## Programming

With the selector switch in “off” position the screen should look like this:



Press DOWN arrow then ESC. “Program” should be highlighted. If not, use up and down arrows keys to highlight “program”.

Press RIGHT arrow. “Set parameter” will be highlighted. Press OK.

“RinseHotWtr” will be highlighted.

Press RIGHT arrow then press OK. Cursor will flash. Use the up and down arrows to toggle between on/off. Press OK then ESC to save setting and get back to parameter screen

Press DOWN arrow to get to the next parameter to set

“RinseColdWtr” will be highlighted.

Press RIGHT arrow then press OK. Cursor will flash. Use the up and down arrows to toggle between on/off. Press OK then ESC to save setting and go back to parameter screen.

Press DOWN arrow to get to next parameter to set

“RinseVacRun” will be highlighted.

Press RIGHT arrow then press OK. Cursor will flash. Use the right and left arrow keys to move the cursor sideways and the up and down arrows to change the value 0-9 Press OK then ESC to save setting and go back to parameter screen.

Repeat steps for remainder of parameters

Note: Move the cursor all the way to the right to change the time value from s (seconds), m (minutes) & h (hours).

**Important: When setting the Chemical Pump timers, make sure the time value is set to seconds or minutes, NOT hours. Chemical pumps have a max run time of 10 min. If set for more, an alarm will be activated after max time allowed.**

# Parameters and Functions

## Rinse Cycle Parameters

RinseHotWtr = Hot water on or off during fill cycle

RinseColdWtr = Cold water on or off during fill cycle

RinseVacRun = Run time for vacuum pump (min/sec)

RinseAddHot = Length of time for adding hot water after initial fill (min/sec).  
Starts after vacuum pump starts up.

RinseAddCold = Length of time for adding cold water after initial fill (min/sec).  
Starts after vacuum pump starts up.

RinseDivDel = Delay time for diverter signal after vacuum pump starts (min/sec).

RinseDivOn = Run time for diverter (min/sec)

RinseDrainOn = Run time for drain (min/sec)

RinseMilkPmp = Run time for milk pump/air blow (min/sec)  
Starts at the same time as end of cycle time.

RinseEndCyc = Wait time before next cycle starts (min/sec)

## Detergent Cycle Parameters

DetHotWtr = Hot water on or off during fill cycle

DetChemPump = Run time for chemical pump (min/sec)

DetSanPump = Run time for sanitizer pump (min/sec)

DetVacRun = Run time for vacuum pump (min/sec)

DetAddHot = Length of time for adding hot water after initial fill (min/sec).  
Starts after vacuum pump starts up.

AddDetDel = Delay from when vacuum pump starts until detergent is added.  
(This one and the next 3 features are for an undersized vat when chemical needs to be added after vacuum pump starts.)

AddDetOn = Run time for chemical pump after "AddDetDel" expires (min/sec)

AddDetSanDel = Delay from when vacuum pump starts until sanitizer is added.

AddDetSanOn = Run time for chemical pump after "AddDetSanDel" expires.

Cont. on next page

DetDivDel = Delay time for diverter signal after vacuum pump starts (min/sec).

DetDivOn = Run time for diverter (min/sec)

DetDrainOn = Run time for drain (min/sec)

DetMilkPmp = Run time for milk pump/air blow (min/sec)  
Starts at the same time as end of cycle time.

DetEndCyc = Wait time before next cycle starts (min/sec)

### **Acid Cycle Parameters**

AcidHotWtr = Hot water on or off during fill cycle

AcidColdWtr = Cold water on or off during fill cycle

AcidChemPump = Run time for chemical pump (min/sec)

AcidVacRun = Run time for vacuum pump (min/sec)

AcidAddHot = Length of time for adding hot water after initial fill (min/sec).  
Starts after vacuum pump starts up.

AcidAddCold = Length of time for adding cold water after initial fill (min/sec).

AddAcidDel=Delay from when vacuum pump starts until acid is added (min/sec).

AddAcidOn=Run time for Acid pump after “AddAcidDel” expires .(min/sec)

AcidDivDel = Delay time for diverter signal after vacuum pump starts (min/sec).

AcidDivOn = Run time for diverter (min/sec)

AcidDrainOn = Run time for drain (min/sec)

AcidMilkPmp = Run time for milk pump/air blow (min/sec)  
Starts at the same time as end of cycle time.

AcidEndCyc = Wait time before next cycle starts (min/sec)  
If Pre-milk sanitize time is selected, display will show time of Pre-sanitize start after this delay.

### **Sanitize Cycle Parameters**

PrMlkSan = Pre-milk sanitize on or off

PrMlkSanTime = Set up day of week and time of day for pre-milk sanitize.

If manual pre-sanitize is preferred:

When “PrMlkSan” is set to “On” and there is no day or time set in “PrMlkSanTime” the controller will not sanitize until it is manually advanced. Press the “Wash Start” switch for 2 seconds to advance. (Only applies after wash cycle is completed.)

Cont. on next page

SanHotWtr = Hot water on or off during fill cycle

SanColdWtr = Cold water on or off during fill cycle

SanChemPump = Run time for chemical pump (min/sec)

SanVacRun = Run time for vacuum pump (min/sec)

SanAddHot = Length of time for adding hot water after initial fill (min/sec).  
Starts after vacuum pump starts up.

SanAddCold = Length of time for adding cold water after initial fill (min/sec).  
Starts after vacuum pump starts up.

AddSanDel=Delay from when vacuum pump starts until sanitizer is added (min/  
sec.

AddSanOn=Run time for sanitize pump after "AddSanDel" expires (min/sec)

SanDivDel = Delay time for diverter signal after vacuum pump starts (min/sec).

SanDivOn = Run time for diverter (min/sec)

SanDrainOn = Run time for drain (min/sec)

SanMilkPmp = Run time for milk pump/air blow (min/sec)  
Starts at the same time as end of cycle time.

SanEndCyc = Time before display shows wash completed (min/sec)

### General Settings Parameters

AirInjOn = On time for air injector (min/sec)

AirInjOff = Off time for air injector (min/sec)

**Note: If you use external timer, set "on" time for length of cycle (in minutes), set "off" time to "0"**

OverFillAlrm = Set timer to approx. 10 min longer than longest cycle. This timer monitors the length of the cycle. If cycle takes longer than preset time, this timer will shut the system down and activate alarm output. Ex: Slow water fill, failing drain, etc

AdvEngStart = To set advanced start of engine before vacuum pump output is energized (Only applies in milk mode)

WashDelay = To set delayed wash start

PowderDet = For use with Powdered Detergents so all hot water will be routed through detergent jar.

SwOffDrainOn = Timer that turns on the drain output for a user-selected amount of time when the Milk/Wash switch is turned to OFF. (For NC Drains)

## Operating Instructions

On the front cover, there is a selector switch for MILK/OFF/WASH and a push button to start wash cycle.

Turn switch to MILK when ready to start milking.

Turn switch to WASH then push the START button when ready to start wash cycle.

Press and hold the START button for 2 seconds to advance to next segment of cycle. Release. Repeat as necessary.

LED lights on the front cover indicate which output is energized.

## Inside the Enclosure

On the I/O board, there is 1 red push button on the top right side labeled “Manual Advance”. Press to advance through the segments in each cycle.

Bottom row of red push buttons are for testing outputs.

Note: Green LED lights will NOT come on when pushed, therefore you will need to use your multimeter to test voltage on outputs.

On the I/O board there is a terminal for milk and wash safety switches. If safety switches are not used, leave jumpers in terminals.

Engine run signal is a dry contact that will control the starter on your engine. Engine will stay on through complete cycle. To avoid overloading engine on start up, “AdvEngStart” parameter can be programmed to delay the vacuum pump “on” signal.

Fill switch is 24Vdc and can be wired for both a float style or pressure style level switch. Note: Fill switch must be activated for 2 seconds before signal is acknowledged

Controller has one field replaceable surge protector to protect against power surges. It is installed in the top left corner of the controller by the black (L1) and red (L2/N) terminal blocks. If it has blown, remove it for temporary bypass. A replacement surge protector is # 40009. One spare # 40009 is included.

On the upper left side of the board (next to the power supply), there is a 3amp glass fuse to protect the board. Extra fuses are included.

## To change Drain and Diverter Valves from NO to NC

Install a wire into black terminals L1(hot) and route to I4 for NC drain valve and I5 for NC diverter valve as shown in picture below

Note: Wire is not supplied.

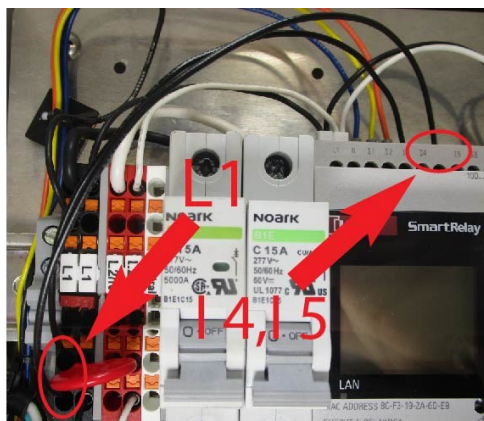

I4,I5 for normally closed  
drain & diverter valve

## Technical Support

Electronics 610.273.7016 Toll Free:888.768.3928

Gert:920.602.6724 (After hours)

EZee Main:717.768.7560 Toll Free:888.880.3933



## Setting Date & Time

To set the date and time, press “Setup” (Located below “Program”) then press “clock”. If “clock” is not showing press “Switch to Admin”, the password is IDEC. Then press “Set Clock” to set date and time.

Note: Smart relay can be set to either “Admin” or “OP” mode. When in “Admin” mode, date and time can be set. When in “OP” mode, date and time can not be set.

## List of All Cycle Parameters and Preprogrammed Settings

Parameter	Preprogrammed Settings	User Settings	User Settings
RinseHotWtr	On		
RinseColdWtr	On		
RinseVacRun	5:00 min		
RinseAddHot	0:00 min		
RinseAddCold	0:00 min		
RinseDivDel	0:00 min		
RinseDivOn	5:00 min		
RinseDrainOn	4:00 min		
RinseMilkPmp	0:00 min		
RinseEndCyc	0:30 min		
DetHotWtr	On		
DetChemPump	2:00 min		
DetSanPump	0:00 min		
DetVacRun	8:00 min		
DetAddHot	0:00 min		
AddDetDel	0:00 min		
AddDetOn	0:00 min		
AddDetSanDel	0:00 min		
AddDetSanOn	0:00 min		
DetDivDel	6:00 min		
DetDivOn	2:00 min		
DetDrainOn	6:00 min		
DetMilkPmp	0:00 min		
DetEndCyc	0:30 min		

Parameter	Preprogrammed Settings	User Settings	User Settings
AcidHotWtr	Off		
AcidColdWtr	On		
AcidChemPump	1:00 min		
AcidVacRun	6:00 min		
AcidAddHot	0:00 min		
AcidAddCold	0:00 min		
AddAcidDel	0:00 min		
AddAcidOn	0:00 min		
AcidDivDel	4:00 min		
AcidDivOn	2:00 min		
AcidDrainOn	4:00 min		
AcidMilkPmp	0:00 min		
AcidEndCyc	0:30 min		
PrMlkSan	Off		
PrMlkSanTime	None		
SanHotWtr	Off		
SanColdWtr	On		
SanChemPump	1:00 min		
SanVacRun	6:00 min		
SanAddHot	0:00 min		
SanAddCold	0:00 min		
AddSanDel	0:00 min		
AddSanOn	0:00 min		
SanDivDel	4:00 min		
SanDivOn	2:00 min		
SanDrainOn	4:00 min		
SanMilkPmp	0:00 min		
SanEndCyc	0:30 min		

Parameter	Preprogrammed Settings	User Settings	User Settings
AirInjOn	8:00 min		
AirInjOff	0:00 min		
OverfillAlrm	10:00 min		
AdvEngStart	0:00 min		
WashDelay	0:00 min		
PowderDet	Off		
SwOffDrainOn	0:00 min		

## Input/Output Wiring diagram

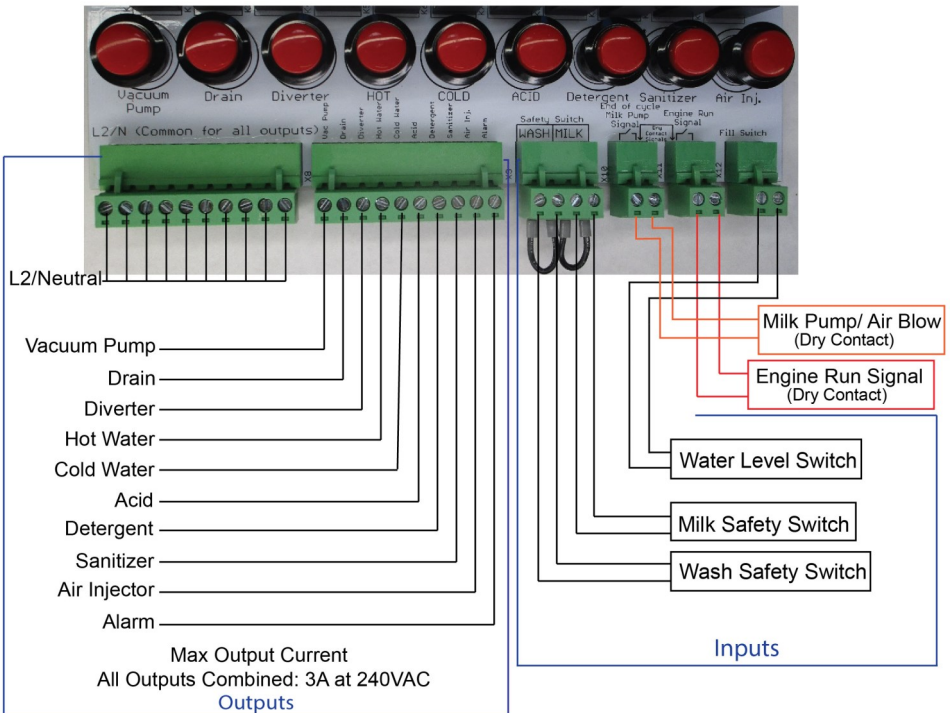

## Troubleshooting

Alarm Message or Problem	Possible cause	Action
Screen displays “Check Fuses and Milk Safety Sw”	<ol style="list-style-type: none"> <li>1. 3A or 5A fuse is blown</li> <li>2. Switch not installed, but will be used.</li> <li>3. Switch is not activated.</li> <li>4. Switch is not wired properly.</li> <li>5. Switch is faulty.</li> <li>6. Switch will not be used, but Jumper not in.</li> </ol>	<ol style="list-style-type: none"> <li>1. Replace any bad fuses</li> <li>2. Install Limit Switch.</li> <li>3. Correct milk line position.</li> <li>4. Inspect wiring.</li> <li>5. Replace switch.</li> <li>6. Install Jumper wire to bypass switch</li> </ol>
Screen displays “Check Fuses and Wash Safety Sw”	<ol style="list-style-type: none"> <li>1. 3A or 5A fuse is blown</li> <li>2. Switch not installed, but will be used.</li> <li>3. Switch is not activated.</li> <li>4. Switch is not wired properly.</li> <li>5. Switch is faulty.</li> <li>6. Switch will not be used, but Jumper not in.</li> </ol>	<ol style="list-style-type: none"> <li>1. Replace any bad fuses</li> <li>2. Install Limit Switch.</li> <li>3. Correct wash line position.</li> <li>4. Inspect wiring.</li> <li>5. Replace switch.</li> <li>6. Install Jumper wire to bypass switch</li> </ol>
Chemical Pumps don't start filling when the water does	<ol style="list-style-type: none"> <li>1. Unit has built in timer that delays chemical.</li> <li>2. Chemical Pump is not wired properly.</li> </ol>	<ol style="list-style-type: none"> <li>1. Wait 30 seconds after water starts</li> <li>2. Inspect wiring</li> </ol>
Screen displays “Overfill alarm is active”	<ol style="list-style-type: none"> <li>1. “OverfillAlarm” time was set too short.</li> <li>2. Water valves are not working properly.</li> <li>3. Fill Switch not activating.</li> <li>4. Water Supply issue.</li> </ol>	<ol style="list-style-type: none"> <li>1. Change setting to longer time.</li> <li>2. Inspect wiring to valves. Use Test Mode.</li> <li>3. Replace or repair Fill Switch.</li> <li>4. Inspect water-supply system.</li> </ol>
Circuit breaker/s are tripping	<ol style="list-style-type: none"> <li>1. Overvoltage protection Red MOV is bad.</li> <li>2. Red MOV on circuit board is bad.</li> </ol>	<ol style="list-style-type: none"> <li>1. Remove and replace the MOV going from black terminals “L1 to red terminals “L2”</li> <li>2. Replace the circuit board</li> </ol>

# Inside the enclosure wiring diagram

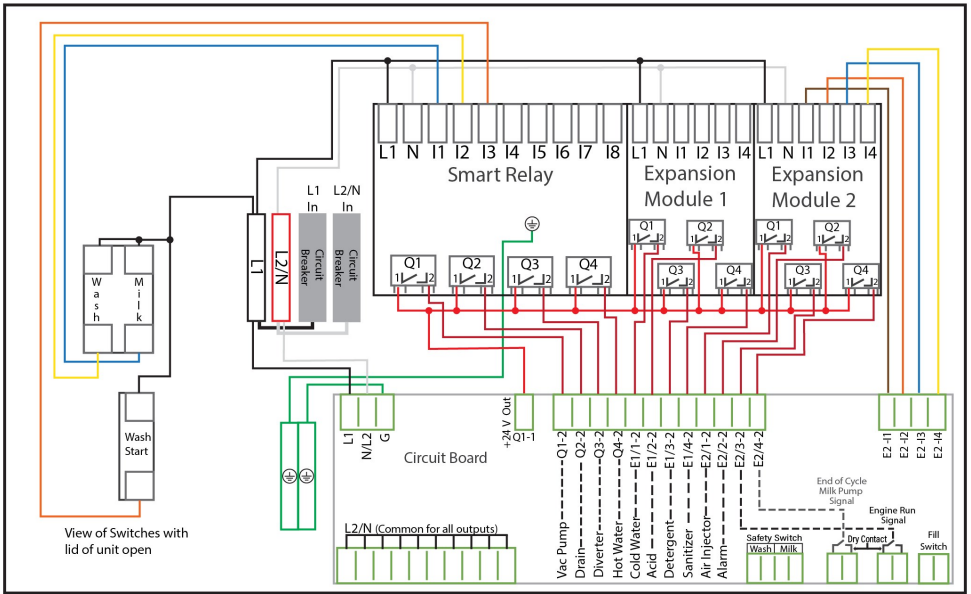

## Notes



**Eco-Wave**  
**Automatic Pipeline Washer**  
*Installation & Operation Manual*

*Rev 4.26*

#40001

---

**888.880.3933**

**[www.ezmilking.com](http://www.ezmilking.com)**

---